

# Extruded Dock Bumpers

## Benefits

- Installs easily.
- Eliminates costly and unsightly damage to equipment, vehicles and structures.
- Resistant to all types of weather.
- One piece construction.
- One year warranty.

## Material/Thickness

- Made of solid rubber for medium and heavy-duty protection.
- All bumpers have impact resistance (ASTM 2632) of 75% with a durometer reading of 70 plus or minus 5.
- D-4 and D-6 available with steel mounting bars.

## Installation

- Anchor bolts easily installed through pre-drilled holes into dock.

## Specifications

- Furnish and install extruded rubber dock bumpers as manufactured by Durable Corporation, Norwalk, Ohio. Model No(s) \_\_\_\_\_.
- Resilient molded nylon and polyester reinforced rubber as well as rubber bumpers.
- Bumpers are made of rubber with a durometer reading of 70 plus or minus 5. Tensile strength of 1,850 PSI with an elongation of 220%. The tear strength (ASTM 624) is 229 pounds per inch with impact resistance (ASTM 2632) of 75%.

| Model             | A Thickness | B Height | Length    | Bolt Size     | Wt. lbs.   | Color |
|-------------------|-------------|----------|-----------|---------------|------------|-------|
| D-2               | 1-3/4"      | 2"       | Up to 10' | 1/4" x 2"     | 1.4 lbs/ft | Black |
| D-4               | 4"          | 4-1/4"   | Up to 10' | 1/2" x 3"     | 3 lbs/ft   | Black |
| D-6               | 6"          | 6"       | Up to 10' | 1/2" x 3"     | 8.5 lbs/ft | Black |
| E 1 1/2" (38.1mm) | 1-1/2"      | 8"       | Up to 10' | 3/8" x 3-3/4" | 6.5 lbs/ft | Black |

NOTE: All dimensions are approximate.

## Uses/Applications

- Appropriate for outdoor or indoor protection.
- For commercial loading docks, parking garages, and marinas.
- For vehicles such as tow trucks, trailers and heavy duty construction equipment.
- In-plant wall protection from forklifts and other material handling vehicles.

## Features

- Variety of styles available for greater flexibility.
- Can be pre-drilled for immediate installation.

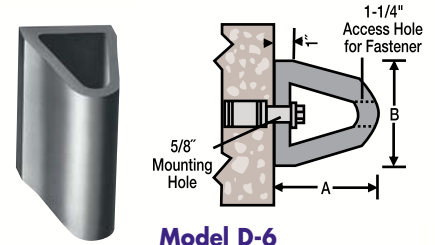

Model D-6

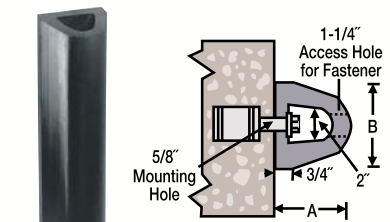

Model D-4

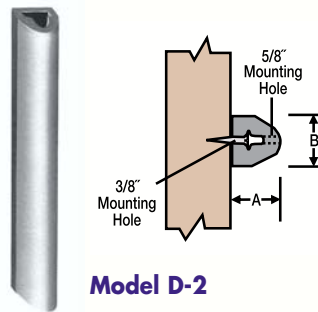

Model D-2

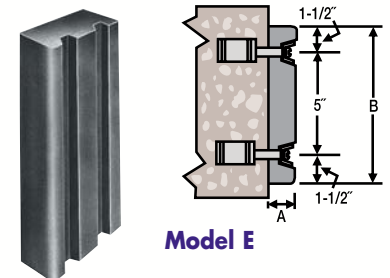

Model E

# Corner Guards

## Benefits

- Easy installation.
- Maintenance free.
- Tough and long-lasting in severe weather.
- One year warranty.

## Material/Thickness

- Made of all natural rubber.
- 7/8" thick at corner.

## Installation

- Adhesive and/or mechanical fasteners for permanent protection.

| Model | Thickness | A Width | Length    | Weight lbs. | Color |
|-------|-----------|---------|-----------|-------------|-------|
| CG-1  | 7/8"      | 4"      | Up to 10' | 2.6 lbs/ft  | Gray  |
| CG-2  | 7/8"      | 4"      | Up to 10' | 2.6 lbs/ft  | Black |

## Uses/Applications

- Wide variety of uses in industrial and commercial applications to withstand abrasion and jolts.
- Provide maximum protection in storage spaces, parking garages and loading docks.

## Features

- Mounted vertically or horizontally along the corners of walls or beams to prevent damage.
- Heavy-duty flexible compound prevents damage to equipment and vehicles to save money.

