



Steel-Face Dock Bumpers

Benefits

- Eliminates wear from up-and-down friction movement of trailers loading and unloading.
- Cost-effective due to longer wear expectancy and fewer replacement costs.
- Impervious to weather damage.
- Maintenance free.
- 5 year warranty.

Material/Thickness

- Fabric reinforced pads cut from selected recycled truck tires
- Standard pad thickness at 4-1/2" and 6" thick. Heights at 6", 10", and 12".
- Steel-face is 3/8" thick, heavy-duty, high carbon steel that is mounted to standard laminated dock bumper.
- Also available in extra-thick sizes of 9", 10-1/2", and 12" projections.

Installation

- Structural mounting angles permit welded installations or provide bolting through steel.
- No assembly required.

Specifications

- Furnish and install Durable Steel-Face Dock Bumpers as manufactured by Durable Corporation, Norwalk, Ohio. Model No(s)_____. Resilient rubber material cut to uniform size pads 4-1/2" thick with overall projection of 5-1/4" [other pad thicknesses available: 6", 9", 10 1/2", and 12"]. Punched to receive 3/4" supporting rods.
- Bumper to have 3/8" steel-face plate equal to the rubber surface dimensions. Plate to be welded to two slotted steel support plates which extend back to the 3/4" supporting rods. Brackets to be punched with elongated slots to allow steel-face to move on impact.
- Finish to be black only.



Uses/Applications

- Ideal for use in docking areas where excessive friction from up-and-down trailer movement occurs.
- Can be used in any material-handling system area where heavy-duty protection is required.

Features

- Available ability to deflect and absorb shock with standard laminated bumper beneath the steel-face.
- Comes in a wide variety of models, and can be mounted in various heights, from flush mount to 12" above dock, depending on highest impact area.

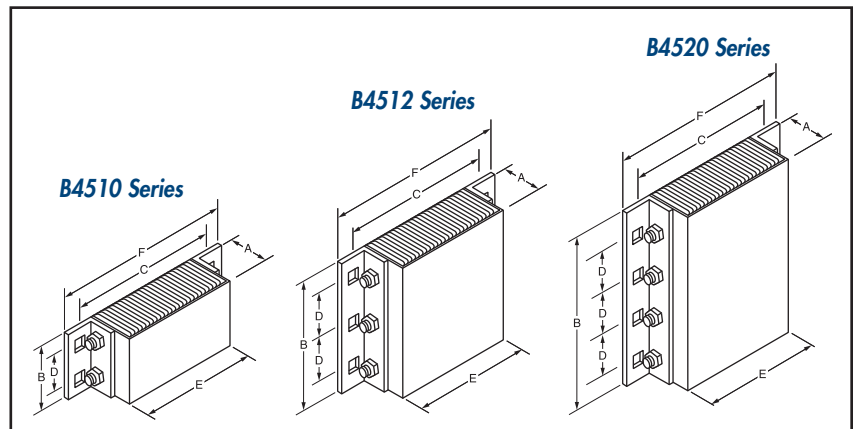

Model	Projection x Height x Bolt Hole Centers (Length) (A x B x C) Size	D Vertical Bolt Hole Centers	E Rubber Length	F Overall Length	Wt. lbs.
B4510-14-SF	5-1/4" x 10" x 14"	6"	10"	16"	48
B4510-18-SF	5-1/4" x 10" x 18"	6"	14"	20"	58
B4510-24-SF	5-1/4" x 10" x 24"	6"	20"	26"	73
B4510-36-SF	5-1/4" x 10" x 36"	6"	32"	38"	72
B4512-14-SF	5-1/4" x 12" x 14"	4"	10"	16"	35
B4512-18-SF	5-1/4" x 12" x 18"	4"	14"	20"	44
B4512-24-SF	5-1/4" x 12" x 24"	4"	20"	26"	58
B4512-36-SF	5-1/4" x 12" x 36"	4"	32"	38"	84
B4520-11-SF	5-1/4" x 20" x 11"	6"	7"	13"	73
B4524-11-SF	5-1/4" x 24" x 11"	4"	7"	13"	56
B4536-11-SF	5-1/4" x 36" x 11"	4"	7"	13"	85
B610-14-SF	6-3/4" x 10" x 14"	6"	10"	16"	33
B610-18-SF	6-3/4" x 10" x 18"	6"	14"	20"	40
B610-24-SF	6-3/4" x 10" x 24"	6"	20"	26"	55
B610-36-SF	6-3/4" x 10" x 36"	6"	32"	38"	82
B612-14-SF	6-3/4" x 12" x 14"	4"	10"	16"	39
B612-18-SF	6-3/4" x 12" x 18"	4"	14"	20"	50
B612-24-SF	6-3/4" x 12" x 24"	4"	20"	26"	72
B612-36-SF	6-3/4" x 12" x 36"	4"	32"	38"	105
B620-11-SF	6-3/4" x 20" x 11"	6"	7"	13"	53
B624-11-SF	6-3/4" x 24" x 11"	4"	7"	13"	64
B636-11-SF	6-3/4" x 36" x 11"	4"	7"	13"	100

NOTE: Available in 9" thick pads with an overall 9 3/4" projection. Other standard sizes available.