

Laminated Dock Bumpers

Molded Bumpers



America's Favorite Truck Stop

Wheel Chocks



Dura-Soft Bumper™

Extra-Thick Bumpers



- Steel-Face Bumpers
- Extruded Bumpers
- Corner Guards
- Parking Blocks
- Speed Bumps

The Durable Advantage

History

Since 1923, Durable Corporation has been recycling tires into quality products. As the leading manufacturer of laminated rubber dock bumpers, Durable has the finest protection available for docks, buildings, trucks and cargo.

Durable has expanded this leadership position by adding a complete line of quality, innovative impact protection products: molded, extruded and steel-face bumpers; wall and corner guards; wheel chocks; speed bumps; as well as extra-thick and extra-length bumpers.

This growth and rapid expansion has made Durable the recognized leader in the industry. We are committed to continuing research and development and providing you the best materials available with the latest technology.

That is why we are called "America's Favorite Truck Stop™."

Experience

Durable's extensive experience has made us pioneers in bumpers. Our innovative leadership in the industry created the first laminated bumpers, steel-face laminated bumpers, and our newest patented Dura-Soft Bumper™. It is this pioneering spirit that has created our complete line of tough, quality products.

Facilities

Durable Corporation is a full-service manufacturer located in Norwalk, Ohio.

We are situated in the industrial heartland of North Central Ohio, 50 miles west of Cleveland. Our expanded warehouse and extensive inventory provide prompt shipment of our full line of impact protection products.

Capabilities

As the recognized leader, Durable provides expert engineering assistance. Because docking facilities pose different planning and maintenance problems, we can help you in the proper selection of dock bumpers, corner and wall guards, wheel chocks and speed bumps. Plus, we can help determine the correct product dimensions for your particular application.

Uses and Applications

Durable's complete line of heavy duty impact protection products cover every application for your facilities.

Our products have unlimited applications in factories, warehouses and docks. They can be used for projecting above low docks, as rub rails at the sides of truck wells, as wall and corner guards to protect against forklifts, or applied directly to trucks and equipment. They can be used in any material handling operation where maximum protection is required.

Our commitment to research and development has enabled us to constantly produce cost-effective products for all uses and applications.

Quality Products

Only Durable is the prime industrial source to offer a complete range of quality protection products. Plus, unbeatable service, including our outstanding guarantee. Durable offers:

- Laminated Bumpers
- Steel-Face Bumpers
- Molded/Extruded Bumpers
- Wall/Corner Guards
- Wheel Chocks and Speed Bumps
- Dura-Soft Bumpers™
- Plus, the best Guarantee

Industries We Serve

Durable bumpers can be found in the following industries!

- Major trucklines
- Major airlines
- Trailer manufacturers
- Postal facilities
- U.S. Government facilities
- Institutional buildings

Satisfied Customers

Durable's years of quality and service have made Durable bumpers the most specified bumper in the industry. National chains, shipping companies and the federal government have used and specify Durable as their dock bumper choice.

Service

Durable takes pride in its customer service as well as its quality. We take the extra steps necessary to supply standard and custom sizes. We meet our customer's needs while giving full service!

We also maintain a very large inventory of our complete line of impact protection products to fill your order promptly.

The Durable Guarantee

Durable's well earned reputation for quality is your best guarantee. We back all our products 100%. Any product which fails to meet reasonable service expectations will be replaced on a prorated basis.

Table of Contents

The Durable Advantage	2	Extra-Thick Laminated Bumpers . . .	8
Quality Products	2	Molded Dock Bumpers	9
The Durable Guarantee	2	Extruded Dock Bumpers.	10
Uses and Applications	2	Corner Guards.	10
Selecting Durable Bumpers	3	Wheel Chocks	11
Dura-Soft Bumpers™	4	Parking Blocks	11
Steel-Face Dock Bumpers	5	Speed Bumps.	11
Laminated Rubber Dock Bumpers . .	6	Terms & Conditions.	12
Extra-Length Laminated Bumpers . .	7	Ordering Instructions	12

Select Durable's Experience

Various factors comprise the loading dock system and contribute to the efficient transfer of goods and materials. Dock bumpers, dock levelers, dock lights, dock height, wheel chocks, and door seals or shelters should all be considered when designing a dock system. Contact us, and we will be happy to help you create the most cost-effective bumper system available.

Dock Bumper Arrangements

Most dock bumper installations should have vertical and horizontal coverage of the dock area for complete dock, truck and cargo protection.

For example, protection for an 8' bay is usually best accomplished with two vertical bumpers and one horizontal bumper of standard length. Our optional overlapping arrangements provide continuous protection and minimize installation costs. An additional row guarantees protection for vehicles of various heights.

When dock seals or shelters are used, extra-length, one-piece bumpers will completely seal trucks to the dock protecting cargo and employees from the elements.

Bumper Heights

Durable's standard bumper heights are 6", 10", or 12". The height can be increased by expanding the angle length and "stacking" bumper pads between them to create vertical units—20", 24", and 36".

The primary application for the 6" unit is on lip docks where the dock slab projects beyond the foundation with an impact face of less than 10" high.

The 10" unit is widely used for standard height docks that accommodate standard, or approximately equal-height trucks.

The heavier constructed 12" unit provides greater area and cube of rubber with a stronger steel frame (three connecting rods).

The 20", 24", or 36" vertical heights provide extended depth protection for varying truck heights (Fig. 1) for the lower steel members of trailer bodies. Consider them for docks that accommodate panel and peddle trucks as well as over-the-road trailers.

Vertical units are particularly applicable with truck leveling devices that raise the entire truck to dock level. Combined with horizontal units, (Figs. 3 & 4), vertical units prevent a loaded trailer from prying off the shorter bumpers as the truck bed rises while being unloaded (Fig. 2).

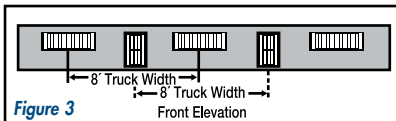
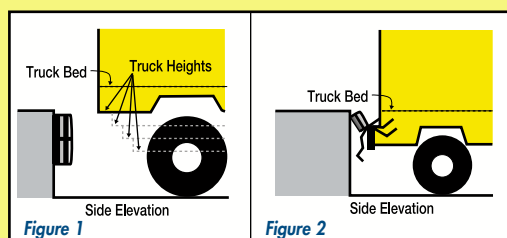

Figure 3

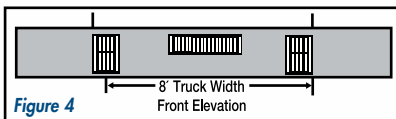

Figure 4

For Open Docks

For open docks with no predetermined truck spots, combination installations provide maximum protection (Fig. 3).

If 36" horizontal length units are used, maximum spacing should be 24" between units—5' on centers (Fig. 6).

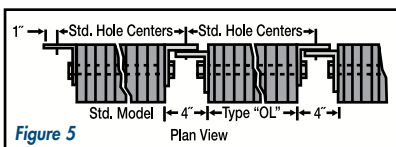

Figure 5

For an angled truck approach, spacing should be reduced to prevent a truck corner from contacting the dock between units.

If continuous bumper protection is needed, overlapping installations on common anchor bolts are recommended and reduce anchor bolt costs by 50% (Fig. 5).

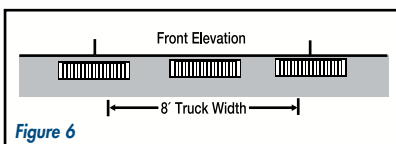

Figure 6

Overlapping reduces the spacing between each bumper to 4", and is applicable to any Durable laminated bumper model.

Overlapping angles on adjacent bumpers cuts installation costs and increases the protected area. To order, specify standard model for first bumper at left, and "OL" construction on successive bumpers. Special-length bumpers to fill out dock spaces are also available.

For open docks or wide bays, extra-length, one-piece bumpers can also be used for maximum coverage and appearance (Fig. 7).

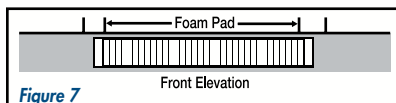

Figure 7

For 8', 9', or 10' Bays

For 8', 9', or 10' bays a variety of combinations exist. We recommend a combination of standard and vertical bumper designs (Fig. 3 & 4) for dock protection.

For Refrigerated Doors

(with or without dock shelters)

Refrigerated doors require 4-1/2" or 6" thick, extra-length, one-piece bumpers to completely seal the truck to the dock or shelter.

The same applies to doors sealed to maintain warm temperatures. With shelters, the rubber surface of the bumper must extend under the vertical members of the shelter pad to complete the all-around seal (Fig. 7).

For Portable Dock Plates

A 36" unit mounted in the center of the dock will automatically allow for dock plate insertion, even if a truck is spotted against the bumpers at the dock. With 3" angles on all bumpers, a 6" space is provided between units for the legs of the dock plate. Continue to fill the width of the bay with standard or vertical units as needed.

For Adjustable Dock Boards

If using 14" lengths, height should be minimum 12", (Figs. 8a, 8b). Most dock boards handle 4-1/2" or 6" thick bumpers and will not impair lip penetration into the truck.

If using horizontal bumpers, use similar to 24" units but with steel plate replacing the inboard angle. Fig. 9 shows damage from "short spacing". Fig. 10 shows "lateral safety zone" impact absorption advantage provided by longer bumpers.

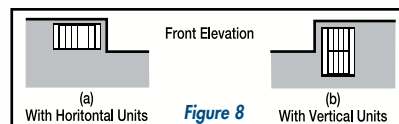

Figure 8

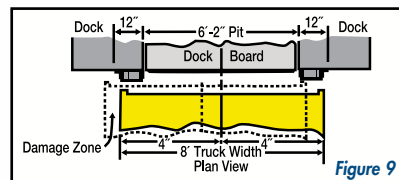

Figure 9

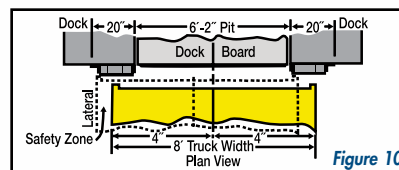

Figure 10

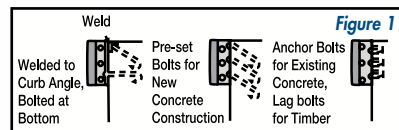
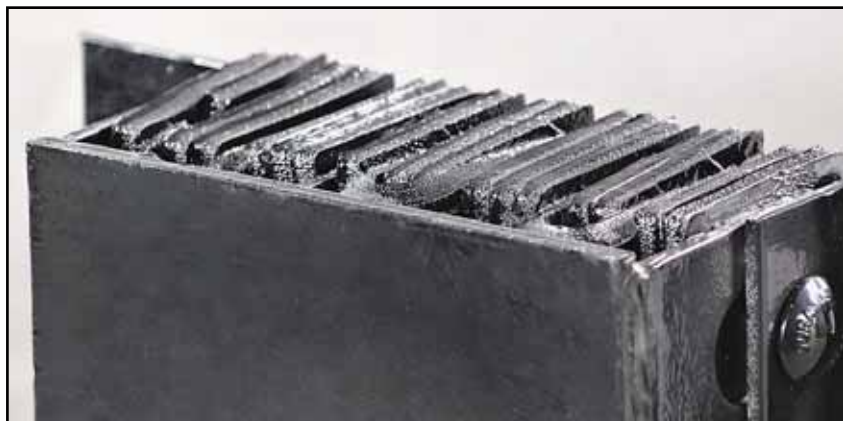

Figure 11

Bumper Installation

Install bumpers (Fig. 11) 1" to 2" below dock level. Use 3/4" or 5/8" lag bolts or sleeve anchors; minimum length 3" and use corresponding shield if required. Use 3/4" "J" bolts with a minimum length of 8" with 1-1/4" projection.



Uses/Applications

- Provides maximum protection with a unique "loop" design of bumper pads—the greatest impact absorption available on the market. Loop-design laminated bumper is a Durable industry innovation.
- Durable's patented design has been thoroughly tested to prove that it provides maximum protection while maintaining the high-quality, heavy-duty dock and truck protection expected of a Durable bumper.
- Steel-Face plate makes the Dura-Soft Bumper™ ideal for use in docking areas where excessive friction from up-and-down trailer movement occurs.
- Can be used in any material-handling system area where heavy-duty protection is required.

Features

- Unparalleled ability to deflect and absorb shock with loop design laminated bumper beneath a floating steel-face.
- Available in a wide variety of models, and can be mounted in various heights, from flush mount to 12" above dock, depending on highest impact area.

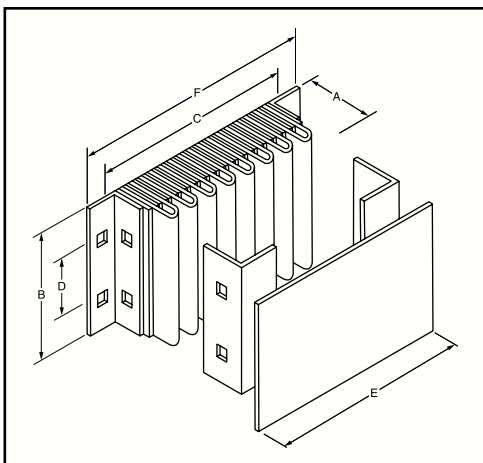

Benefits

- Maximum dock and truck protection available.
- Eliminates wear from up-and-down friction movement of trailer loading and unloading.
- Impervious to weather damage.
- Maintenance free.
- 5 year warranty.
- Cost effective.

Material/Thickness

- Rubber pads 4" thick with loop pad and 3/8" steel-face for overall thickness at 5-1/2".

Installation

- Structural mounting angles permit welded installations or provide bolting through steel.
- No assembly required.

Specifications

- Furnish and install Durable Dura-Soft Bumpers™ as manufactured by Durable Corporation, Norwalk, Ohio. Model No(s) _____.
- Resilient rubber material of bumpers shall be cut to uniform size pads 4" thick with overall projection of 5-1/2". Longer, looped pads inserted between standard spacer pads to allow approximately 1/2" flex of looped pads upon impact. Pads punched to receive 3/4" supporting rods.
- Bumper to have 3/8" steel-face plate equal to the rubber surface dimensions. Plate to be welded to slotted steel support plates which extend back to the 3/4" supporting rods. Brackets to be punched with elongated slots to allow steel-face to "float" on impact.
- Finish to be black only.

Model	Projection x Height x Bolt Hole Centers (Length) (A x B x C) Size	D Vertical Bolt Hole Centers	E Rubber Length	F Overall Length	Wt. lbs.
B5510-14-DS	5-1/2" x 10" x 14"	6"	10"	16"	48
B5510-18-DS	5-1/2" x 10" x 18"	6"	14"	20"	58
B5510-24-DS	5-1/2" x 10" x 24"	6"	20"	26"	73
B5510-36-DS	5-1/2" x 10" x 36"	6"	32"	38"	72
B5512-14-DS	5-1/2" x 12" x 14"	4"	10"	16"	35
B5512-18-DS	5-1/2" x 12" x 18"	4"	14"	20"	44
B5512-24-DS	5-1/2" x 12" x 24"	4"	20"	26"	58
B5512-36-DS	5-1/2" x 12" x 36"	4"	32"	38"	84
B5520-11-DS	5-1/2" x 20" x 11"	6"	7"	13"	73
B5524-11-DS	5-1/2" x 24" x 11"	4"	7"	13"	56
B5536-11-DS	5-1/2" x 36" x 11"	4"	7"	13"	85



Steel-Face Dock Bumpers

Benefits

- Eliminates wear from up-and-down friction movement of trailers loading and unloading.
- Cost-effective due to longer wear expectancy and fewer replacement costs.
- Impervious to weather damage.
- Maintenance free.
- 5 year warranty.

Material/Thickness

- Fabric reinforced pads cut from selected recycled truck tires
- Standard pad thickness at 4-1/2" and 6" thick. Heights at 6", 10", and 12".
- Steel-face is 3/8" thick, heavy-duty, high carbon steel that is mounted to standard laminated dock bumper.
- Also available in extra-thick sizes of 9", 10-1/2", and 12" projections.

Installation

- Structural mounting angles permit welded installations or provide bolting through steel.
- No assembly required.

Specifications

- Furnish and install Durable Steel-Face Dock Bumpers as manufactured by Durable Corporation, Norwalk, Ohio. Model No(s)_____. Resilient rubber material cut to uniform size pads 4-1/2" thick with overall projection of 5-1/4" [other pad thicknesses available: 6", 9", 10 1/2", and 12"]. Punched to receive 3/4" supporting rods.
- Bumper to have 3/8" steel-face plate equal to the rubber surface dimensions. Plate to be welded to two slotted steel support plates which extend back to the 3/4" supporting rods. Brackets to be punched with elongated slots to allow steel-face to move on impact.
- Finish to be black only.



Uses/Applications

- Ideal for use in docking areas where excessive friction from up-and-down trailer movement occurs.
- Can be used in any material-handling system area where heavy-duty protection is required.

Features

- Available ability to deflect and absorb shock with standard laminated bumper beneath the steel-face.
- Comes in a wide variety of models, and can be mounted in various heights, from flush mount to 12" above dock, depending on highest impact area.

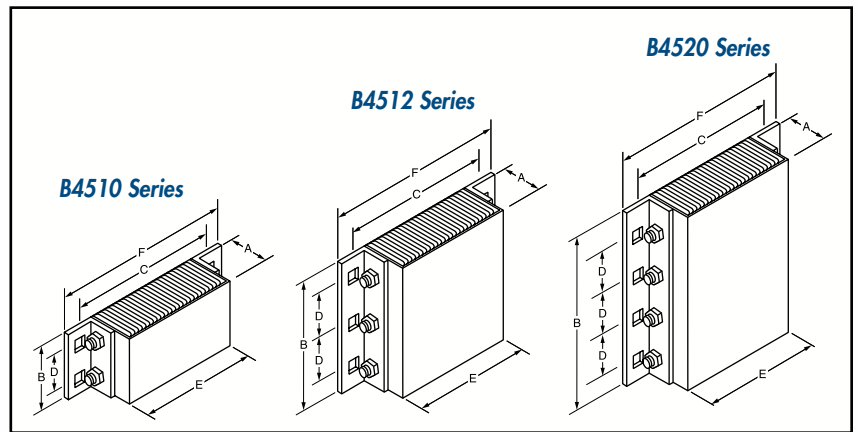

Model	Projection x Height x Bolt Hole Centers (Length) (A x B x C) Size	D Vertical Bolt Hole Centers	E Rubber Length	F Overall Length	Wt. lbs.
B4510-14-SF	5-1/4" x 10" x 14"	6"	10"	16"	48
B4510-18-SF	5-1/4" x 10" x 18"	6"	14"	20"	58
B4510-24-SF	5-1/4" x 10" x 24"	6"	20"	26"	73
B4510-36-SF	5-1/4" x 10" x 36"	6"	32"	38"	72
B4512-14-SF	5-1/4" x 12" x 14"	4"	10"	16"	35
B4512-18-SF	5-1/4" x 12" x 18"	4"	14"	20"	44
B4512-24-SF	5-1/4" x 12" x 24"	4"	20"	26"	58
B4512-36-SF	5-1/4" x 12" x 36"	4"	32"	38"	84
B4520-11-SF	5-1/4" x 20" x 11"	6"	7"	13"	73
B4524-11-SF	5-1/4" x 24" x 11"	4"	7"	13"	56
B4536-11-SF	5-1/4" x 36" x 11"	4"	7"	13"	85
B610-14-SF	6-3/4" x 10" x 14"	6"	10"	16"	33
B610-18-SF	6-3/4" x 10" x 18"	6"	14"	20"	40
B610-24-SF	6-3/4" x 10" x 24"	6"	20"	26"	55
B610-36-SF	6-3/4" x 10" x 36"	6"	32"	38"	82
B612-14-SF	6-3/4" x 12" x 14"	4"	10"	16"	39
B612-18-SF	6-3/4" x 12" x 18"	4"	14"	20"	50
B612-24-SF	6-3/4" x 12" x 24"	4"	20"	26"	72
B612-36-SF	6-3/4" x 12" x 36"	4"	32"	38"	105
B620-11-SF	6-3/4" x 20" x 11"	6"	7"	13"	53
B624-11-SF	6-3/4" x 24" x 11"	4"	7"	13"	64
B636-11-SF	6-3/4" x 36" x 11"	4"	7"	13"	100

NOTE: Available in 9" thick pads with an overall 9 3/4" projection. Other standard sizes available.

Laminated Rubber Dock Bumpers

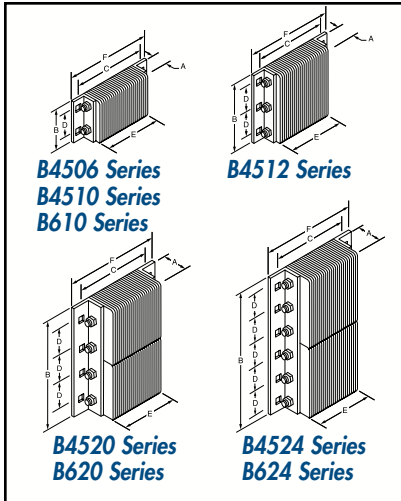

Uses/Applications

- Available in two models: bumpers with angles for most applications—equipped with 1/4" steel angles on both ends; and bumpers with flat plate for use with dock levelers—optional 1/4" flat steel plate for one or both ends.
- Have unlimited applications in factories, warehouses and docks.
- Vehicle impact protection for loading docks.
- Projecting above low docks.

Features

- Rub rails at the sides of truck wells.
- Wall bumpers to protect against fork lift trucks.
- Special construction features to accommodate unusual anchoring conditions.
- Tough plies of truck tire material virtually eliminates chipping or abrasion, unlike molded rubber, extruded rubber, conveyor belting or wood plank bumpers.
- Attractive deep black color enhances a neat, professional architectural look.
- Manufactured under pressure exceeding 1,500 lbs. to absorb over 80% of impact force.
- Anchor bolts are protected by at least 3" of rubber to prevent damage.

Benefits

- Provides protection against vehicle damage to docks, buildings and cargo.
- Absorbs over 80% of truck impact and shock to protect dock and building.
- Leading bumper sold in the industry today.
- Standard sizes shipped within 24 hours.
- Eliminates costly repairs from severe shock to docks.
- Constructed to last and provide years of protection.
- Anchored through thick steel angles to provide stability and shape retention.
- Performs on any truck dock under any weather condition or prolonged exposure.
- Maintenance free. 5 year warranty.

Material/Thickness

- Fabric reinforced rubber pads cut from selected recycled truck tires.
- Rubber pads laminated between structural steel angles and secured with 3/4" steel tie rods.
- Rubber pads 4-1/2" or 6" thick.

Model	Projection x Height x Bolt Hole Centers (Length) (A x B x C) Size	D Vertical Bolt Hole Centers	E Rubber Length	F Overall Length	Wt. lbs.
B4506-24	4-1/2" x 6" x 24"	3"	20"	26"	28
B4506-36	4-1/2" x 6" x 36"	3"	32"	38"	42
B4510-12	4-1/2" x 10" x 12"	6"	8"	14"	25
B4510-14	4-1/2" x 10" x 14"	6"	10"	16"	26
B4510-18	4-1/2" x 10" x 18"	6"	14"	20"	34
B4510-24	4-1/2" x 10" x 24"	6"	20"	26"	45
B4510-36	4-1/2" x 10" x 36"	6"	32"	38"	66
B4512-12	4-1/2" x 12" x 12"	4"	8"	14"	31
B4512-14	4-1/2" x 12" x 14"	4"	10"	16"	32
B4512-18	4-1/2" x 12" x 18"	4"	14"	20"	41
B4512-24	4-1/2" x 12" x 24"	4"	20"	26"	56
B4512-36	4-1/2" x 12" x 36"	4"	32"	38"	82
B4520-11	4-1/2" x 20" x 11"	6"	7"	13"	42
B4524-11	4-1/2" x 24" x 11"	4"	7"	13"	51
B4536-11	4-1/2" x 36" x 11"	4"	7"	13"	85
B610-12	6" x 10" x 12"	6"	8"	14"	29
B610-14	6" x 10" x 14"	6"	10"	16"	33
B610-18	6" x 10" x 18"	6"	14"	20"	43
B610-24	6" x 10" x 24"	6"	20"	26"	58
B610-36	6" x 10" x 36"	6"	32"	38"	84
B612-12	6" x 12" x 12"	4"	8"	14"	34
B612-14	6" x 12" x 14"	4"	10"	16"	41
B612-18	6" x 12" x 18"	4"	14"	20"	51
B612-24	6" x 12" x 24"	4"	20"	26"	69
B612-36	6" x 12" x 36"	4"	32"	38"	105
B620-11	6" x 20" x 11"	6"	7"	13"	52
B624-11	6" x 24" x 11"	4"	7"	13"	63
B636-11	6" x 36" x 11"	4"	7"	13"	100

Installation

- Structural mounting angles permit welded installations or provide bolting through steel.

Specifications

- Furnish and install rubber dock bumpers as manufactured by Durable Corporation, Norwalk, Ohio. Model No(s) _____ . Resilient rubber material of bumpers shall be rubberized-fabric truck tires cut to uniform size pads and punched to receive 3/4" supporting rods.
- All bumpers must be 4-1/2" or 6" thick (projection from dock), and closed with two 1/4" structural angles under approximately 1,500 lbs of pressure.
- The anchor leg of angle extends a minimum of 3" beyond the rubber surface at either end and contains two or three 13/16" anchor bolt holes as required. (Anchor bolts are supplied separately.)
- Black finish.
- Galvanized exposed metal or all metal available upon request, surcharges apply.

Extra-Length Laminated Dock Bumpers

Material/Thickness

- Made of tough rubberized fabric pads, 4-1/2" or 6" thick cut from selected recycled truck tires.
- Rubber pads laminated between heavy structural steel angles and secured with 3/4" steel tie rods.

Installation

- Structural mounting angles permit welded installations or provide bolting through steel.
- Four options for anchorage devices for extra-length bumpers.

Specifications

- Furnish and install extra-length laminated rubber dock bumpers as manufactured by Durable Corporation, Norwalk, Ohio. Model No(s)_____. Resilient rubber material of bumpers shall be rubberized-fabric truck tires cut to uniform size pads either 4-1/2" x 10", 6" x 10", 4-1/2" x 12", or 6" x 12". Pads punched to receive 3/4" supporting rods.
- All bumpers are closed with two 1/4" structural angles under approximately 1,500 lbs of pressure. The angles are welded to 3/4" rods at one end and closed with threaded rod and nut at the other end. 1/4" flat plates may be substituted for one or both angles.
- The anchor leg of angle extends a minimum of 3" beyond the rubber surface at either end and contains two or three 13/16" anchor bolt holes as required. (Anchor bolts are supplied separately.)
- Black finish.

Uses/Applications

- Primarily used in conjunction with dock-seal.
- Ideal where dock refrigeration or warmth is needed.

Features

- Dock-seal and bumper interact to totally seal the truck to the dock.
- Provides continuous protection for truck, cargo, dock and shelter to stop wind, snow and rain.
- Custom lengths available.

Benefits

- Prevents loss of refrigeration or warmth.
- Maintenance free—weather resistant.
- Absorbs over 80% of truck impact and shock to protect dock and building.

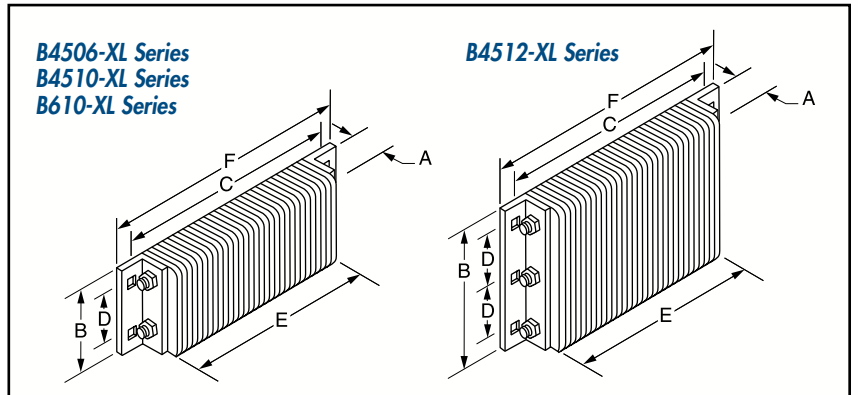
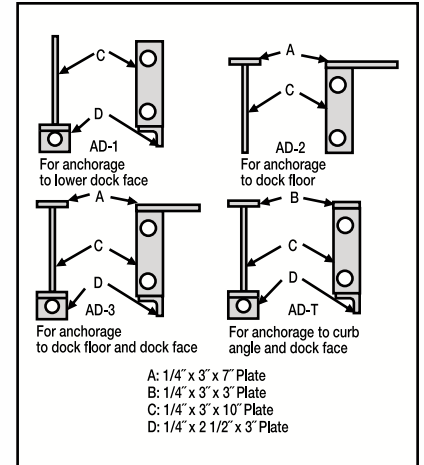

Model	Projection x Height x Bolt Hole Centers (Length) (A x B x C) Size	D Vertical Bolt Hole Centers	E Rubber Length	F Overall Length	Wt. lbs.
B4506-87-A*	4-1/2" x 6" x 7'3"	3"	6'-11"	7'-5"	98
B4506-99-A*	4-1/2" x 6" x 8'3"	3"	7'-11"	8'-5"	121
B4510-51-A*	4-1/2" x 10" x 4'3"	6"	3'-11"	4'-5"	101
B4510-63-A*	4-1/2" x 10" x 5'3"	6"	4'-11"	5'-5"	124
B4510-75-A*	4-1/2" x 10" x 6'3"	6"	5'-11"	6'-5"	147
B4510-87-A*	4-1/2" x 10" x 7'3"	6"	6'-11"	7'-5"	172
B4510-99-A*	4-1/2" x 10" x 8'3"	6"	7'-11"	8'-5"	193
B4510-111-A*	4-1/2" x 10" x 9'3"	6"	8'-11"	9'-5"	218
B4510-123-A*	4-1/2" x 10" x 10'3"	6"	9'-11"	10'-5"	238
B4512-51-A*	4-1/2" x 12" x 4'3"	4"	3'-11"	4'-5"	120
B4512-63-A*	4-1/2" x 12" x 5'3"	4"	4'-11"	5'-5"	148
B4512-75-A*	4-1/2" x 12" x 6'3"	4"	5'-11"	6'-5"	175
B4512-87-A*	4-1/2" x 12" x 7'3"	4"	6'-11"	7'-5"	202
B4512-99-A*	4-1/2" x 12" x 8'3"	4"	7'-11"	8'-5"	230
B4512-111-A*	4-1/2" x 12" x 9'3"	4"	8'-11"	9'-5"	258
B4512-123-A*	4-1/2" x 12" x 10'3"	4"	9'-11"	10'-5"	284

*Refer to illustration AD-1, AD-2, AD-3 or AD-T for type of anchorage device. AD-3 is standard unless otherwise specified.
NOTE: 6" projection also available in standard sizes.

Extra-Thick Laminated Dock Bumpers

Uses/Applications

- Where greater "stand out" distance from dock sills is required due to steep ramps, canopied docks, overhangs or other architectural features.

Features

- Consists of tough plies of truck tire fabric which virtually eliminates chipping or abrasion.

Benefits

- Maintenance free, weather resistant.
- Prevents damage to trucks, loading docks and buildings by providing greater stand-out distance from dock sills on steep ramps.
- Protects dock seals from over-compression.

Special Notes

- Refer to stand-out distance planner to choose proper thickness for incline docks.
- Extra-Thick bumpers are not warranted due to specialty applications where they are used.

**B920 Series
B10520 Series
B1220 Series**

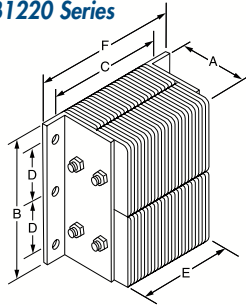

**B910 Series
B10510 Series
B1210 Series**

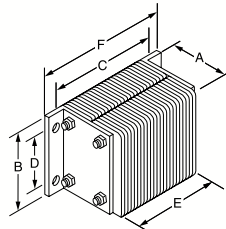

Material/Thickness

- Uniform size, fabric reinforced rubber pads cut from selected recycled truck tires in 9", 10-1/2", and 12" projections.

Installation

- Structural mounting angles permit welded installations or provide bolting through steel (as opposed to bolting through rubber).
- No assembly required.

Specifications

- Furnish and install extra-thick laminated rubber dock bumpers as manufactured by Durable Corporation, Norwalk, Ohio. Model No(s) _____.
- Resilient rubber material of bumpers shall be rubberized truck tires cut to uniform size pads, in stand-out thicknesses of 9", 10-1/2" or 12", punched to receive 3/4" steel tie rods.
- All bumpers are closed with two 1/4" steel formed angles under approximately 1,500 lbs of pressure. 1/4" flat plates may be substituted for one or both angles.
- Anchor leg of angle extends a minimum of 3" beyond the rubber surface at either end and contains two or three 13/16" anchor bolt holes as required. (Anchor bolts are supplied separately). Finish for exposed metal parts is either chrome aluminum lead-free enamel, or hot-dipped galvanized.

Model	Projection x Height x Bolt Hole Centers (Length) (A x B x C) Size	D Vertical Bolt Hole Centers	E Rubber Length	F Overall Length	Wt. lbs.
B910-14	9" x 10" x 14"	6"	10"	16"	63
B910-24	9" x 10" x 24"	6"	20"	26"	98
B910-36-A3*	9" x 10" x 36"	6"	32"	38"	152
B920-11	9" x 20" x 11"	6"	7"	13"	103
B10510-14	10-1/2" x 10" x 14"	6"	10"	16"	71
B10510-24	10-1/2" x 10" x 24"	6"	20"	26"	109
B10510-36-A3*	10-1/2" x 10" x 36"	6"	32"	38"	167
B10520-11	10-1/2" x 20" x 14"	6"	7"	13"	109
B1210-14	12" x 10" x 14"	6"	10"	16"	76
B1210-24	12" x 10" x 24"	6"	20"	26"	120
B1210-36-A3*	12" x 10" x 36"	6"	32"	38"	195
B11210-11	12" x 20" x 11"	6"	7"	13"	134

*Center anchorage device recommended for 36" long bumpers. A3 standard unless otherwise specified. See illustration on page 7.

Molded Dock Bumpers

Material/Thickness

- Manufactured from fiber reinforced prime rubber containing nylon and polyester.
- Comes in models varying in thickness from 2" to 6".
- All bumpers have impact recovery (ASTM 1170) of 95% with a durometer reading of 80 plus or minus 5.
- Tensile strength: 950-1505 PSI.
- All models have pre-drilled, countersunk mounting holes for easy installation, and are drilled to accept 3/4" anchor bolts.

Installation

- Installation is easy—3/4" anchor bolts are mounted through pre-drilled holes into dock.

Specifications

- Furnish and install molded dock bumpers as manufactured by Durable Corporation, Norwalk, Ohio. Model No(s)_____.
- Molded in one piece of all new nylon and new polyester reinforced rubber.
- Bumper to have a durometer reading of 80 plus or minus 5, tensile strength of 950-1050 PSI, and an impact recovery (ASTM 1170) of 95%.

Uses/Applications

- Perfect protection for any low traffic truck dock.
- In-plant wall protection from forklifts and other material handling vehicles.

Features

- Makes for a clean, neat, attractive dock area.
- Molded in one piece.
- Will not warp, rust, rot or harden.
- Compact size.
- Spectra-Shield Dock Bumper face constructed of Ultra High Molecular

Weight (UHMW) polyethylene recessed into reinforced molded rubber. Call for information and specifications.

Benefits

- Unique design and construction achieves high impact resistance and long life.
- Immune to all weather conditions.
- Maintenance-free.
- Offers the correct amount of resiliency to absorb pressure and impact shock without damage to truck or dock.
- One year warranty

Model T

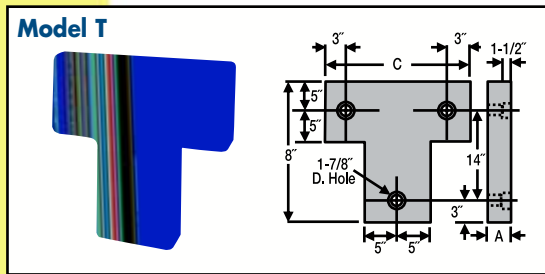

Model R

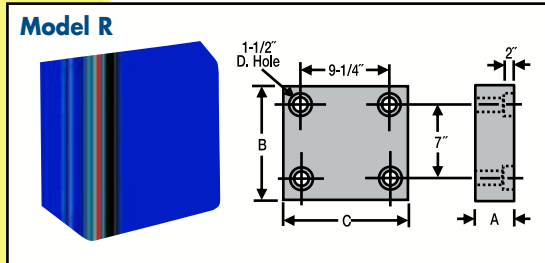

Model L

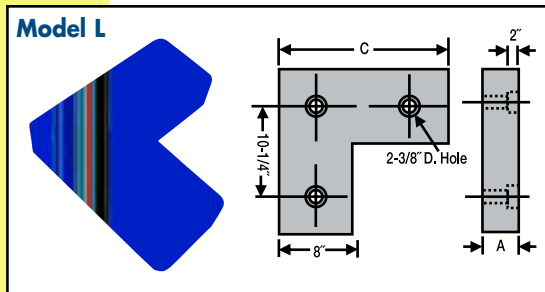

Model M-30

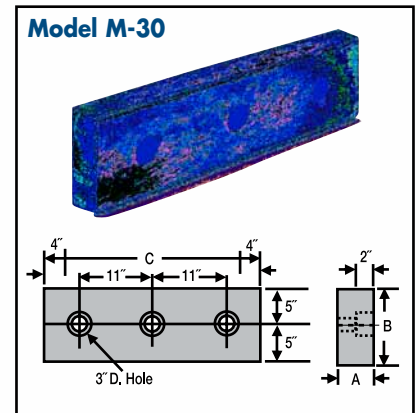

Spectra Shield

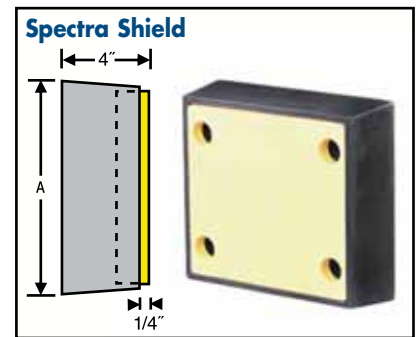

Model M-18

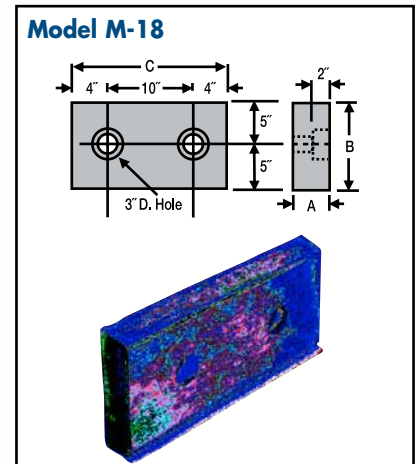

Model B Series

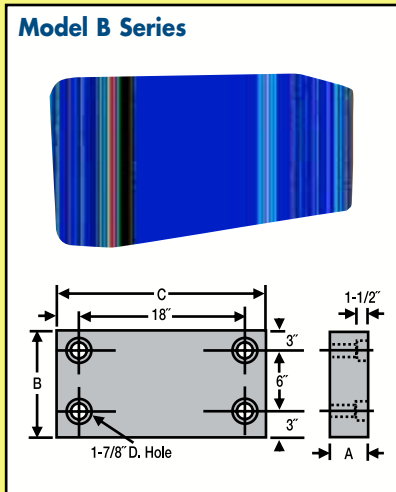

Model	A Thickness	B Height	C Width	Bolt Size	No. of Bolts	Wt. lbs.
T	3"	22"	22"	3/4" x 4"	3	35
L	4"	18"	18"	3/4" x 6"	3	33
R	4"	12"	13"	3/4" x 6"	4	23
M-18	4"	10"	18"	3/4" x 6"	2	27
Spectra Shield SS1213	4"	13"	12"	3/4" x 6"	4	24
B	3"	12"	24"	3/4" x 4"	4	29
BB	4"	12"	24"	3/4" x 6"	4	38
BBB*	6"	12"	24"	3/4" x 6"	4	67
M-30	4"	10"	30"	3/4" x 6"	3	43
DB-13	4"	10"	13"	5" x 6"	2	18

Extruded Dock Bumpers

Model	A Thickness	B Height	Length	Bolt Size	Wt. lbs.	Color
D-2	1-3/4"	2"	Up to 10'	1/4" x 2"	1.4 lbs/ft	Black
D-4	4"	4-1/4"	Up to 10'	1/2" x 3"	3 lbs/ft	Black
D-6	6"	6"	Up to 10'	1/2" x 3"	8.5 lbs/ft	Black
E 1 1/2" (38.1mm)	1-1/2"	8"	Up to 10'	3/8" x 3-3/4"	6.5 lbs/ft	Black

NOTE: All dimensions are approximate.

Uses/Applications

- Appropriate for outdoor or indoor protection.
- For commercial loading docks, parking garages, and marinas.
- For vehicles such as tow trucks, trailers and heavy duty construction equipment.
- In-plant wall protection from forklifts and other material handling vehicles.

Features

- Variety of styles available for greater flexibility.
- Can be pre-drilled for immediate installation.

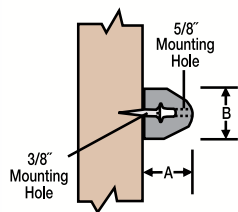
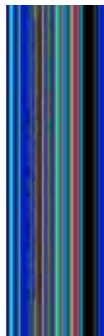

Model D-2

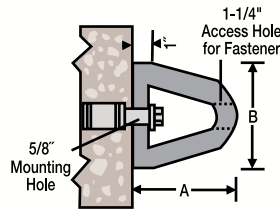

Model D-6

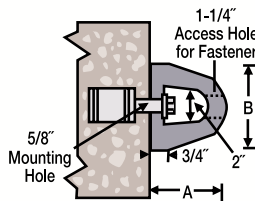

Model D-4

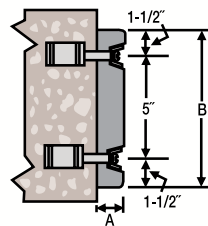

Model E

Benefits

- Installs easily.
- Eliminates costly and unsightly damage to equipment, vehicles and structures.
- Resistant to all types of weather.
- One piece construction.
- One year warranty.

Material/Thickness

- Made of solid rubber for medium and heavy-duty protection.
- All bumpers have impact resistance (ASTM 2632) of 75% with a durometer reading of 70 plus or minus 5.
- D-4 and D-6 available with steel mounting bars.

Installation

- Anchor bolts easily installed through pre-drilled holes into dock.

Specifications

- Furnish and install extruded rubber dock bumpers as manufactured by Durable Corporation, Norwalk, Ohio. Model No(s) _____. Resilient molded nylon and polyester reinforced rubber as well as rubber bumpers.
- Bumpers are made of rubber with a durometer reading of 70 plus or minus 5. Tensile strength of 1,850 PSI with an elongation of 220%. The tear strength (ASTM 624) is 229 pounds per inch with impact resistance (ASTM 2632) of 75%.

Corner Guards

Uses/Applications

- Wide variety of uses in industrial and commercial applications to withstand abrasion and jolts.
- Provide maximum protection in storage spaces, parking garages and loading docks.

Features

- Mounted vertically or horizontally along the corners of walls or beams to prevent damage.
- Heavy-duty flexible compound prevents damage to equipment and vehicles to save money.

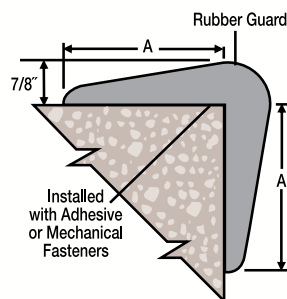

Benefits

- Easy installation.
- Maintenance free.
- Tough and long-lasting in severe weather.
- One year warranty.

Material/Thickness

- Made of all natural rubber.
- 7/8" thick at corner.

Installation

- Adhesive and/or mechanical fasteners for permanent protection.

Model	Thickness	A Width	Length	Weight lbs.	Color
CG-1	7/8"	4"	Up to 10'	2.6 lbs/ft	Gray
CG-2	7/8"	4"	Up to 10'	2.6 lbs/ft	Black

Wheel Chocks

Model 88-8 *Premium*

- Extra heavy-duty.
- Laminated rubber pads assembled on 3/4" bolts and compressed between 1/4" steel plates.
- Contoured to fit tire.
- Fully meets OSHA requirements.
- Reversible.
- 5 year warranty.

NOTE: Also available with gripper cleats for better traction in snow, ice, dirt and mud.

Model 68-9

- Molded from tough fiber-reinforced rubber compound.
- Well suited for trailer trucks and other heavy equipment.
- One year warranty.

Model 811-7

- Light weight yet heavy duty.
- Molded urethane chock contoured to fit truck tires.
- Designed to grip both the tire and the pavement.
- Will not harm macadam.
- One year warranty.

Model SC-8

- Light weight, non-sparking extruded aluminum.
- Surface gripping teeth on underside.
- One year warranty.

Other models available. Please call for information and pricing on models not listed.

OSHA Specifies:

1910.178 (k) Trucks and railroad cars. (1) The brakes of highway trucks shall be set and wheel chocks placed under the rear wheels to prevent the trucks from rolling while they are boarded with powered industrial trucks.

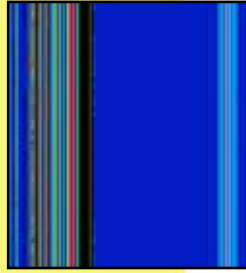

Model 88-8



Model SC-8

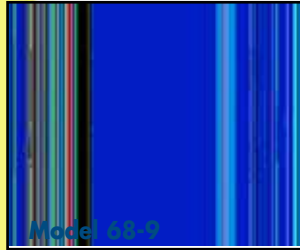

Model 68-9



Model 68-9 OR



Model 811-7

Safety Accessories

- Safety sign for wall mounting reminds drivers and dock personnel to chock vehicle wheels.
- Chain and bracket secures wheel chock to wall and provides convenient storage location.

Model	Width	Height	Length	Wt. lbs.	Color
88-8	8"	8"	8"	15	Black
68-9	8"	5-3/4"	9"	9	Black
68-9 OR	8"	5-3/4"	9"	11	Orange
811-7	11-3/8"	8-1/4"	7-5/8"	6-1/2	Orange
SC-8	11-5/8"	8"	7"	6-1/4	Aluminum

NOTE: Custom extruded chocks and wedges available upon request.

Parking Blocks/Speed Bumps

Parking Block Benefits

- Easy, one-person installation.
- Maintenance free.
- Maintains attractive colorful appearance year-after-year.

Material

- 100% recycled, heavy-duty plastic.

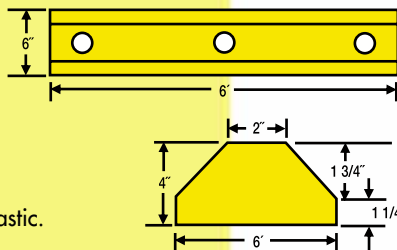

Parking Block Features

- Made of 100% recycled, heavy-duty plastic.
- Available in three colors: safety yellow, handicap blue and gray.
- Light weight, yet durable.
- Optional hardware available.

Speed Bump Benefits

- 10 mile-per-hour design helps protect people and property.
- Easily movable for changing traffic patterns or snow plowing.
- Easy, one-person installation and relocation.
- Maintenance free.
- Less costly than competitive alternatives.

Material

- 100% recycled, heavy-duty plastic.

Benefits

- 5 year warranty

Model	Color	Width	Height	Length	Weight lbs.
RPC-366-BL	Blue	6"	4"	6'	35
RPC-366-GY	Gray	6"	4"	6'	35
RPC-366-YE	Safety Yellow	6"	4"	6'	35

Speed Bumps Features

- Made of 100% recycled, heavy-duty plastic.
- Molded in safety yellow color.
- Light weight, yet indestructible.
- Durable, built for long-lasting service.
- Hardware included.

Model	Width	Height	Length	Weight lbs.
HPR-0072	10"	2"	6'	35

Terms & Conditions

Warranty

All Durable Corporation products are guaranteed to be free of defects in material and workmanship under normal conditions of usage, provided our recommended installation and maintenance instructions are followed. (We will not be liable for damages in excess of the purchase price of the product.)

Terms

Terms are 1% 10, net 30 days, subject to credit approval. A 1-1/2% per month finance charge may be applied to accounts past 30 days.

Pricing

All prices are FOB shipping point.

Prices are subject to change without notice. When price changes are necessary, we will make every effort to provide advance information, allowing reasonable time for customers to make their price adjustments.

Shipping Charge

All orders are FOB shipping point.

Unless specifically requested otherwise, all shipments sent by motor freight will be sent prepaid and added to invoice when shipping from Norwalk, Ohio and all other locations. When necessary shipment may be sent prepaid, with transportation charges sent directly to customer, a service charge may apply. Orders will be shipped via United Parcel Service (UPS) or Federal Express whenever possible. When UPS limits are exceeded, we will always ship the least expensive, most direct way, unless otherwise specified by customer. All weights shown in this catalog are approximate and may vary from one production run to another. **Durable reserves the right to ship product via its desired carriers. If other carriers are specified, special handling charges may apply.**

Product Stability

Every effort has been made to accurately describe our products and to define their general usage. Determination of the suitability of any product and any application contemplated by the Buyer is the sole responsibility of the Buyer or User. In the event of improper product selection by the Buyer, Durable Corporation makes no warranty or guarantee of results to be obtained since use and application by the Buyer are beyond our control. If in doubt as to the suitability

of a particular product application, please contact our Customer Service Department.

Product Specifications

Specifications for all products are approximate and subject to change without prior written notice when such changes are made to achieve improved product appearance, design, or performance.

Color Specifications

Product colors are reproduced in our catalog as accurately as possible. Colors represent average production runs and may vary in shade from time to time, depending upon dye lot and compound variables.

Returned Goods

Every effort will be made to accommodate requests for returned merchandise. Please contact our Customer Service Department for assistance in making arrangements for returns. When return authorization is granted, merchandise must be returned to us freight Prepaid and side marked with the assigned return authorization number. Merchandise must be packaged properly. **A restocking charge of up to 30%** will be enforced on **ALL** standard stock items returned. Durable Corporation determines stock items. Not all products listed in catalogs are considered standard products. **Special size, special run, special color, or custom made materials are not returnable.** Authorizations to return merchandise is valid for sixty (60) days.

Damaged Goods/Shortages

To protect your interest, it is imperative to inspect and count articles before accepting shipment. **Damages or shortages should be documented on the delivery receipt.** If damage of shortage occurs, contact our Customer Service Department for assistance in filing a claim. Filing claims with freight carriers is the responsibility of the consignee. Claims for lost or damaged goods cannot be honored after six (6) months from the date of shipment.

Verbal Quotations

All verbal quotations must be documented with our quotations number. No verbal quotation will be valid without such documentation.

Ordering Instructions

Each product in this catalog includes an item number which specifies the information required for ordering that particular item. It is essential to provide all the information specified to assure shipment of the desired item without delays that might result from incomplete information. For items where length, height, and thickness are to be specified, it is important to note that length is measured from left to right, height is the distance from top to bottom and thickness is the dimension from front to back.

Plates on all styles of laminated bumpers should be specified with a P1 for plate one side or P2 for plate 2 sides after the item number. Laminated bumpers are listed and considered standard with angles on both sides.

Galvanized angles are available. Specify (G) after the item number. Refer to price book for galvanized pricing.



**75 North Pleasant St.
Norwalk, Ohio 44857**

419-668-8138

800-537-1603

Fax 800-537-6287

www.durablecorp.com

Printed on recycled paper

